



**MACHINE
GREATNESS™**

PUMA VTR1216 series



**Large RAM-type
Vertical Turning Center**

PUMA VTR1216 series

PUMA VTR1216
PUMA VTR1216M

ver. EN 170720 SU

Basic Information

Basic Structure

Detailed Information

Options

Applications

Diagrams

Specifications

Customer Support

Service



PUMA VTR1216 series

The PUMA VTR1216 Series is a 50-in. class vertical RAM-type turning center offering the largest table turning diameter of $\varnothing 1600\text{mm}$ (63.0 in.) in its class. Its further extended machining range and enhanced stability are implemented with a rigid and wide column structure.



Contents

02 Product Overview

Basic Information

04 Basic Structure

Detailed Information

07 Standard / Optional Specifications

10 Applications

12 Diagrams

23 Machine / CNC Specifications

26 Customer Support Service

Full Stroke, Wide Machining Range

Single Wide Column Design provides wide machining range comprising Full X-axis (-700/+1000 mm (-27.6/+39.4 inch)) and Z-axis (1200 mm (47.2 inch)) of stroke.

World's first RAM Tool Index System

For the first time in the world, this 2-axis machine tool features a quad-tool-holder-based ram tool index system that enables the use of 4 tools directly via the ram, dispensing with the need to use approach the ATC and thus enhancing productivity.

Improved Productivity with Powerful Cutting Capacity

The high-strength Cr-Mo alloy steel RAM offers 8000kgf of tool clamping force, delivering durability and heavy cutting performance.

Basic Structure

The perfect thermally-symmetric bed and column guarantee powerful, stable, and long-term machining performance over wide machining area.

Structure Designed for High Durability and Machining Stability

Equipped with a wide, one-piece type bed and wide column design, and supported by a large capacity cooler, the PUMA VTR1216 Series guarantees long, powerful, and stable machining performance.

Travel distance

X-axis

-700 / +1000 mm
(-27.6 / +39.4 inch)

Z-axis

1200 mm
(47.2 inch)

W-axis

800 mm
(31.5 inch)



* Series Composition
PUMA VTR1216
PUMA VTR1216M (Milling Spindle)

Machining Area

The largest machining area in its class guarantees highest-level productivity and optimal flexibility in machining large workpieces.

Max. Turning Diameter (D)

Ø1600 mm
(63.0 inch)

Max. Turning Height (H)

1250 mm
(49.2 inch)

Max. Loading Capacity

8000 kg
(17636.7 lb)



Spindle

Provided with a high capacity cooler as standard, the perfectly thermally-symmetric spindle offers heavy and stable precision machining performance on a long-term basis.



RAM Tool

The servo-driven tool magazine offers fast and accurate tool selection.

RAM Indexing

The tool holder's 8 tons of clamping force supports heavy cutting, while Doosan's unique ram indexing technology and quad holder enable the use of 4 tools with 90° rotation without using the ATC, thereby increasing productivity.

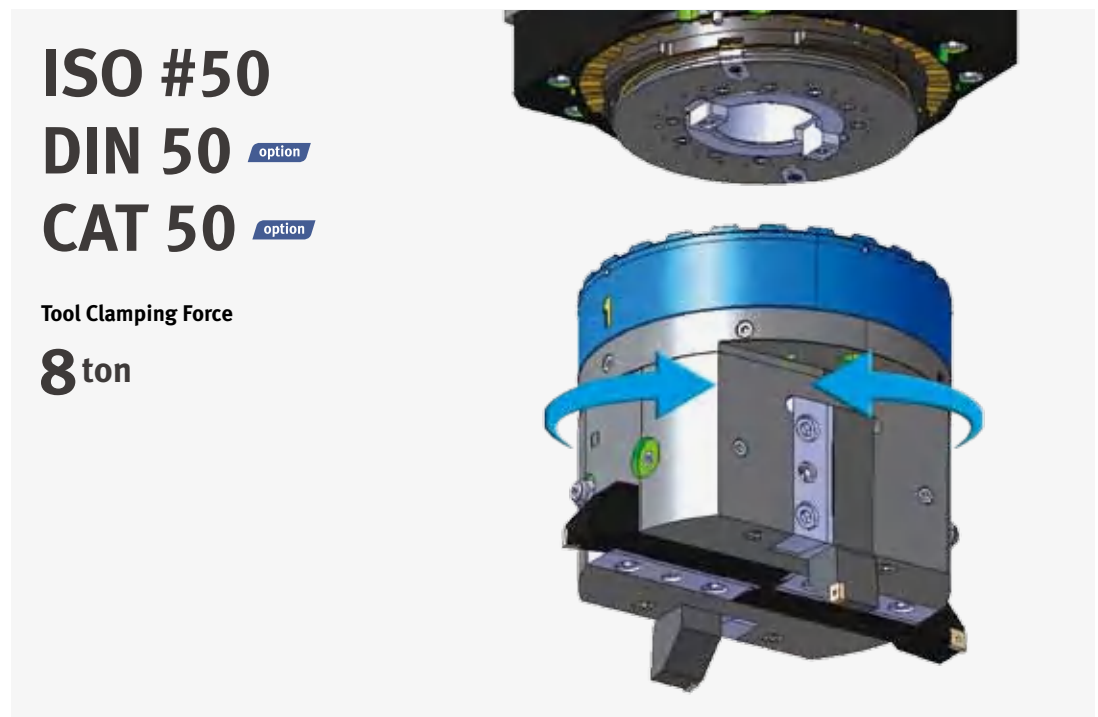

ATC Tool Magazine

The servo-driven ATC tool magazine enables fast and accurate tool selection.



PUMA VTR1216M의 ATC

Max. Tool Storage Capacity

PUMA VTR1216

12,24 ea option

PUMA VTR1216M

16 ea

(7 for turning / 8 for milling / 1 for cap)

34 ea

(12 for turning / 21 for milling / 1 for cap) option

Max. Tool Length

500 mm
(19.7 inch)

ATC Tool Magazine

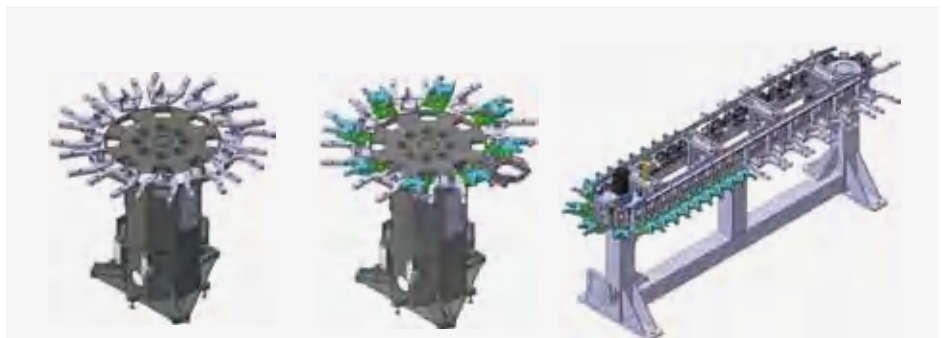

12 ATC

- 12 for turning

16 ATC

- 7 for turning
- 8 for milling
- 1 for cap

34 ATC

- 12 (1 ~ 24) for turning
- 21 (2 ~ 45) for milling
- 1 for cap



Standard/Option Specifications

Various optional features are available for specific work applications.

● Standard ○ Optional X Not applicable

NO.	Description	Features	PUMA VTR1216	PUMA VTR1216M	
1	MAIN SPINDLE	A40/6000_45/37 kW (60.3/49.6 Hp)	●	●	
2		A40HV/7000_70/45/37 kW (93.9/60.3/49.6 Hp)	○	○	
3	Rotary Cylinder Type	NONE	●	●	
4		LONG STROKE_YAST-250S	○	○	
5	CHUCK	CHUCK ADAPTER ONLY_D720 mm (28.3 inch)	○	○	
6		1250 mm (50 inch)_MANUAL 4-JAW	●	●	
7		1400 mm (55 inch)_MANUAL 4-JAW	○	○	
8		1250 mm (50 inch)_COMBINATION	○	○	
9		1400 mm (55 inch)_COMBINATION	○	○	
10		1250 mm (50 inch)_POWER 3-JAW	○	○	
11		1400 mm (55 inch)_POWER 3-JAW	○	○	
12	Soft Top Jaws	NONE	●	●	
13		MANUAL-4 EA	○	○	
14		MANUAL-8 EA	○	○	
15		COMBINATION-7 EA	○	○	
16		COMBINATION-14 EA	○	○	
17		POWER-3 EA	○	○	
18		POWER-6 EA	○	○	
19	Hard Top Jaws	NONE	●	●	
20		MANUAL-4 EA	○	○	
21		COMBINATION-7 EA	○	○	
22		POWER-3 EA	○	○	
23	Tool Shank Type	BIG PLUS BT50	X	○	
24		BIG PLUS CAT50	X	○	
25		BIG PLUS DIN50	X	○	
26	TOOL STORAGE CAPACITY	12 EA	●	X	
27		24 EA	○	X	
28		16 EA (TURN-7 EA/MILL-8EA/CAP-1 EA)	X	●	
29		34 EA (TURN-12 EA/MILL-21EA/CAP-1 EA)	X	○	
30	Coolant pump for RAM	1.8 kW_0.7 Mpa_30 L/min (2.4 Hp_0.7 Mpa_30 L/min)	●	●	
31		2.5 kW_1.0 Mpa_30 L/min (3.4 Hp_1.0 Mpa_30 L/min)	○	○	
32		1.5 kW_2.0 Mpa_28 L/min (2.0 Hp_2.0 Mpa_28 L/min)	○	○	
33		2.2 kW_7.0 Mpa_14 L/min (3.0 Hp_7.0 Mpa_14 L/min)	○	○	
34	Coolant options	High coolant interface	○	○	
35		Oil Skimmer (Belt type)	○	○	
36		Coolant flow switch	○	○	
37		Coolant level switch	○	○	
38	Chip Disposal Options	Rear chip conveyor	Hinged belt	○	○
39			Magnetic scrapper	○	○
40		Chip bucket	Folklift 380L	○	○
41			Rotation 380L	○	○
42		Chip processing options	Coolant gun	○	○
43	Measurement & Automation	Automatic workpiece measurement	RMP60_RENISHAW	○	○
44		Automatic front door and safety devices		○	○
45		Tool Setter (Auto)		○	○
46	Optional Accessories	Doosan tool load monitoring system		●	●
47		Linear scale (X / Z axis)		●	●
48		Auto power off		○	○
49		Gravity axis drop prevention		●	●
50	Air conditioner		○	○	

Various Options

Basic Information

Basic Structure

Detailed Information

- Options
- Applications
- Diagrams
- Specifications

Customer Support Service

Table Chuck option 6~11

Various types of table chucks are offered, including manual type and hydraulic type.

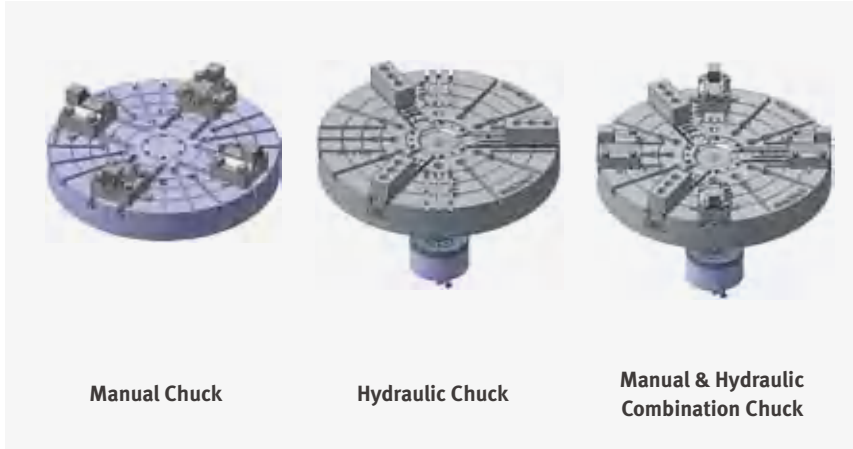

Manual Chuck

Hydraulic Chuck

Manual & Hydraulic Combination Chuck

2-Stage Power Chuck option

A hydraulic power chuck with 4 jaws which are divided into 2 pairs each driven with a 2-stage hydraulic cylinder.



Rear Exit Chip Conveyor option 38~39

Smooth chip disposal is guaranteed with the one-piece-type bed provided with chip discharge channels on both sides of the table and rear exit dual chip conveyors.

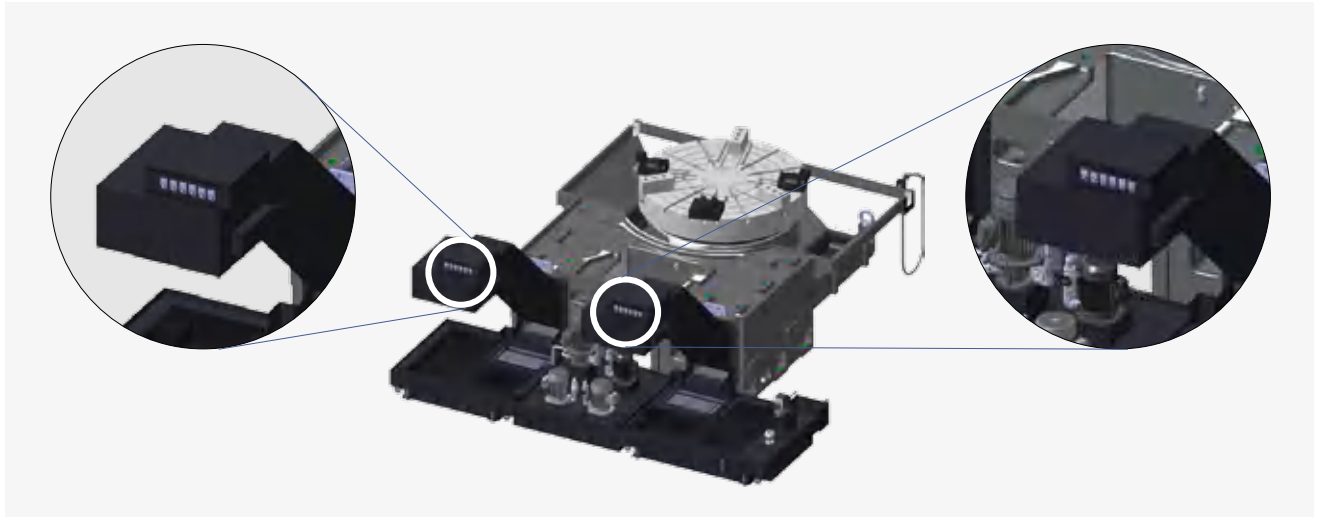

Long



Short



Needle



Sludge

Chip conveyor type	Material	Carbon steel			Cast iron		Aluminium		
		Long	Short	Needle	Short	Sludge	Long	Short	Needle
Hinged belt type		○	△	X	△	X	○	△	X
Magnetic Scrapper type		X	○	○	○	○	-	-	-

○ : Suitable, △ : Possible, X : Not suitable

Automatic Tool Setter option 45

The device automatically measures tool wear and reflects the offset to improve machining accuracy.

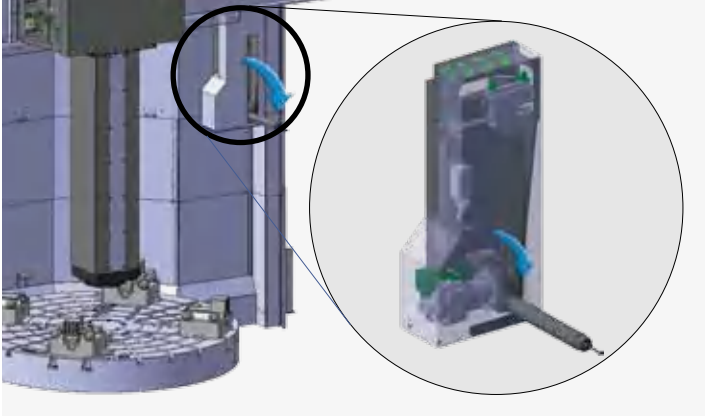

Full cover option

Prevents dust, mist inside the equipment from being discharged to the outside.



Various Tool Options option

Tool options include a 90° angle attachment and grinding unit. The selected tool is driven by a milling tool motor (M model only).

ANGLEATT.



Max. Speed : 3000 r/min
Max. Torque : 404 N·m (298.2 ft-lbs)
Through Tool Coolant : Max. 70bar

GRINDING UNIT



Grinding Wheel : Ø305 mm (12.0 inch)
Max. Speed : 3000 r/min

Linear Scale

X / Z axes linear scales are provided as a standard feature for maximum accuracy.



Internal footrest option

Internal footrest can be set for convenient of setting and maintenance





DOOSAN FANUC i

FANUC CNC has been optimized for DOOSAN's machine tools to maximize productivity.

User friendly operation panel



1. Buttons option

Manual operation buttons for easy maintenance and setting.



2. Display

- Tool No. display - Simultaneous display of tool No. & head tool No.
- Head tool rotation button



3. Portable MPG

- Axis jog feed
- Spindle rotation



4. Hot keys for frequently used functions and a user-friendly button layout.



1. Hot Key
2. Power Saving button for preserving the environment
3. Grouped layout by tools and coolant
4. Spindle and gear speed shift buttons

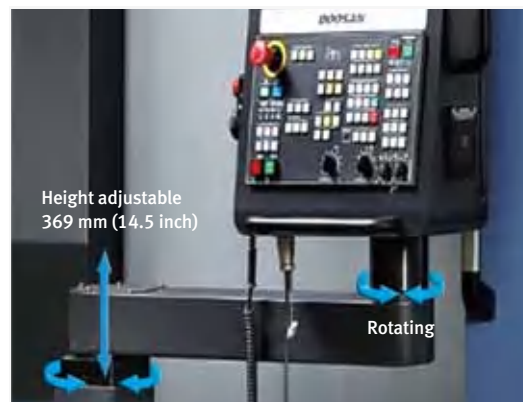

Height adjustable
369 mm (14.5 inch)

Rotating

The operation panel can be raised, lowered, and swivelled for operating convenience.

Easy Operation Package

Doosan's unique Easy Operation Package (EOP) offers tool management function, peripheral device settings, operation, online help, and other functionalities to maximize operational efficiency and user convenience.

ATC Position Compensation

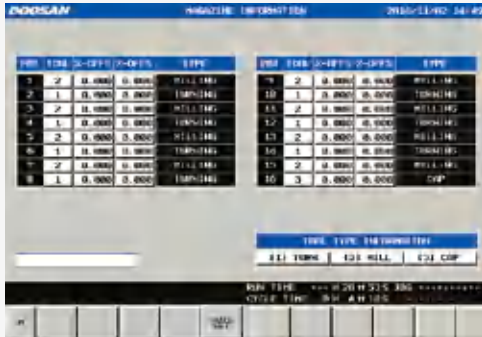

- Tool position change and offset are displayed and set up.
- Easy compensation and prevention against deformation/displacement by long-term operation, etc.

ATC Tool Load Monitoring



- Tool overload is monitored to prevent tool damage.
- Max. allowable load is set up to protect tools
- Real-time-based load monitoring

Alarm Guidance



- Guidance for resetting alarms
- Management of alarm time and history
- Display of solenoid and sensor statuses and locations for easier maintenance

Thermal Error Compensation (PUMA VTR1216M)



- Improved accuracy with thermal displacement compensation
- Real-time-based machine temperature monitoring

EZ-Guide i

Using the DOOSAN EZ-Guide i, users can create a cutting program for any desired shape, including patterns, by entering figures only.

EZ-Guide i screen

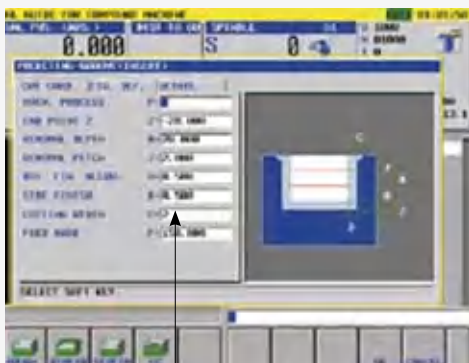

Enter the dimensions of the shape.

Automatic creation of cutting program

```
O7000 (SAMPLE PROGRAM) ;
...
M3 S1500 ;
G0 X50. Y125. ;
G0 Z30. ;
G1040 T0.5 J3. H0.2 K0.5 ... ;
G1020 H120. V50. U37. W68. ... ;
G0 Z80. ;
M5 ;
```

A cutting program is automatically created with the entered values.

Spindle Power – Torque Diagram

Spindle

PUMA VTR1216/M

Max. power

45 kW
(60.3 Hp)

Max. torque

20557 N·m
(15171.1 ft-lbs)

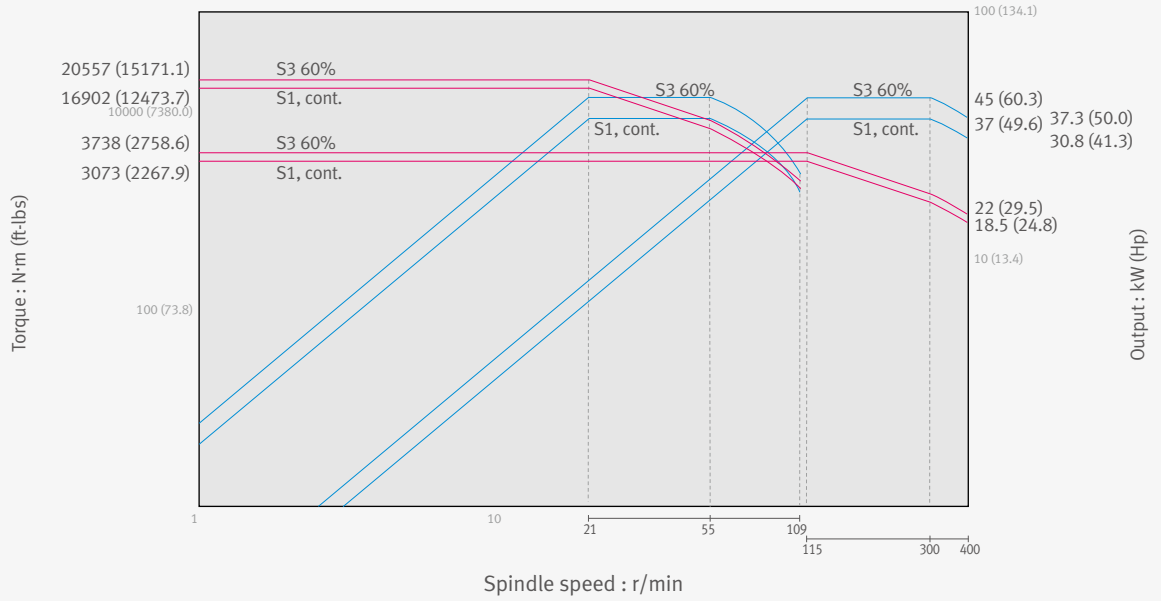

PUMA VTR1216/M **option**

Max. power

70 kW
(93.9 Hp)

Max. torque

31977 N·m
(23599.0 ft-lbs)

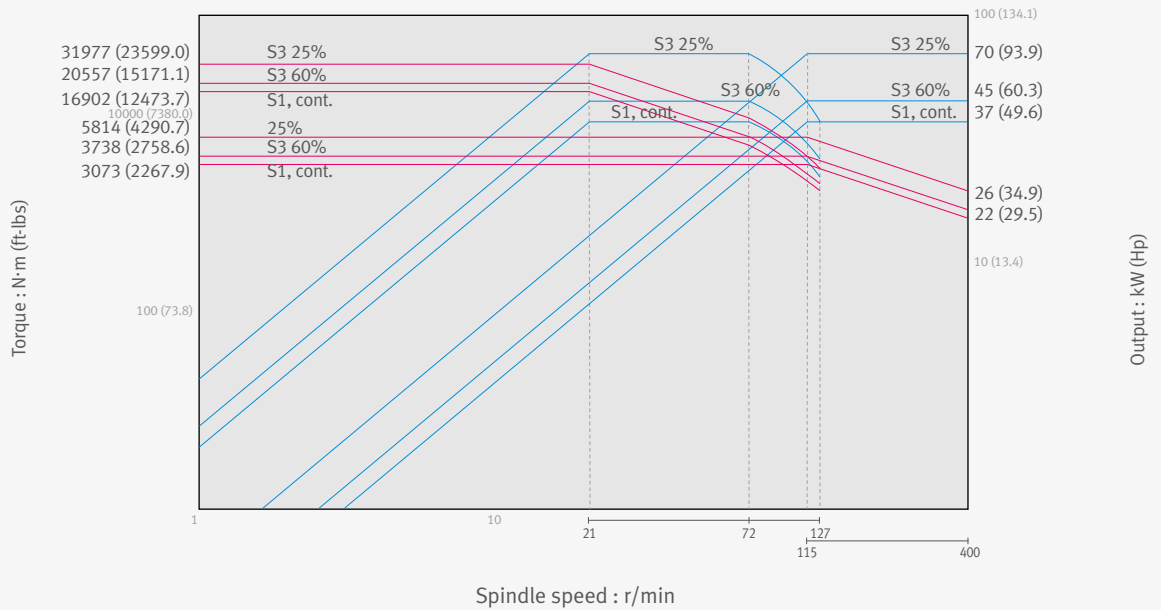

Rotary Tool

PUMA VTR1216M

Max speed of live tool

3000 r/min

Max power of live tool

18.5 kW
(24.8 Hp)

Max. torque

674 N·m
(497.4 ft-lbs)

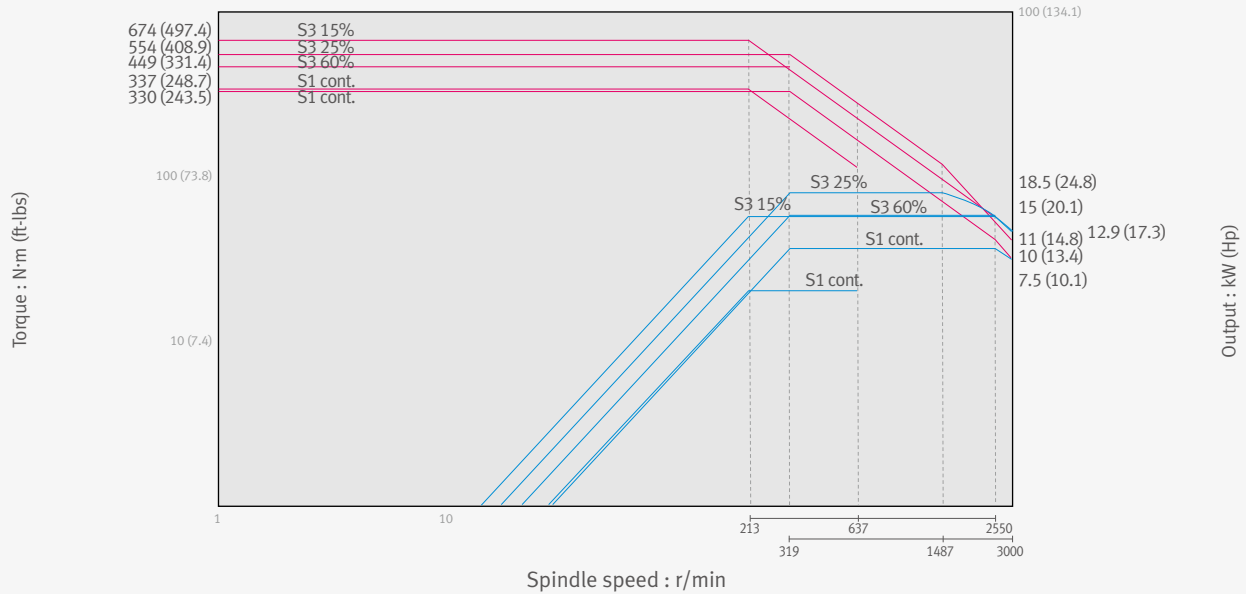

PUMA VTR1216M **option**

Max speed of live tool

3000 r/min

Max power of live tool

15 kW
(20.1 Hp)

Max. torque

674 N·m
(497.4 ft-lbs)

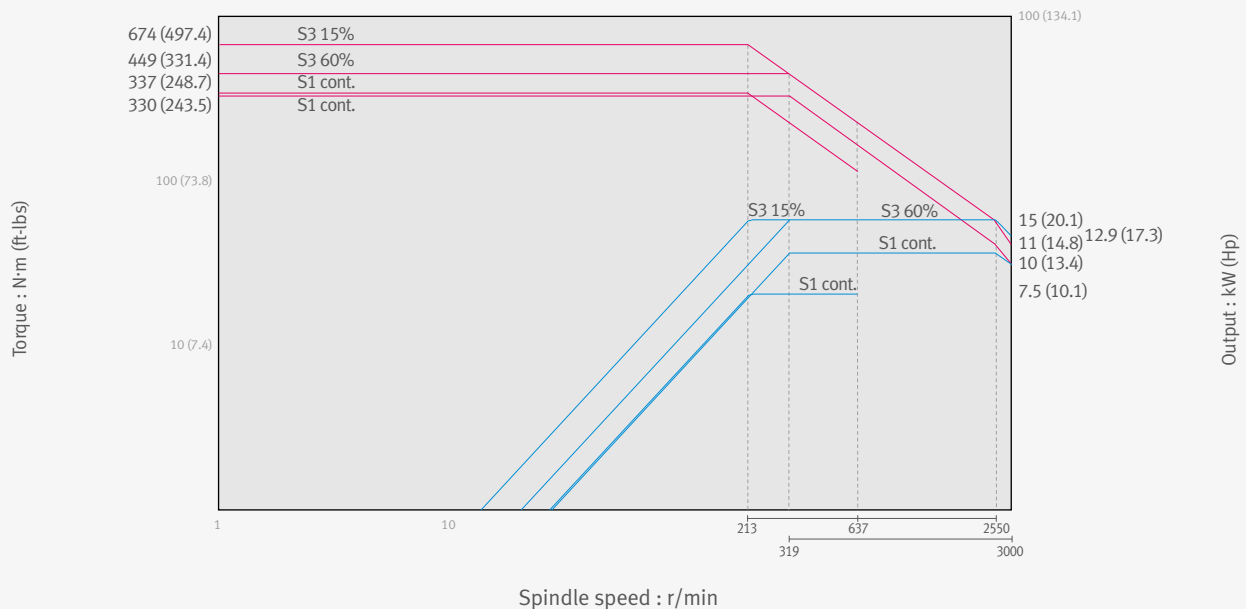

HV(High Voltage) CNC

External Dimensions

PUMA VTR1216/M

Unit: mm (inch)

Top View

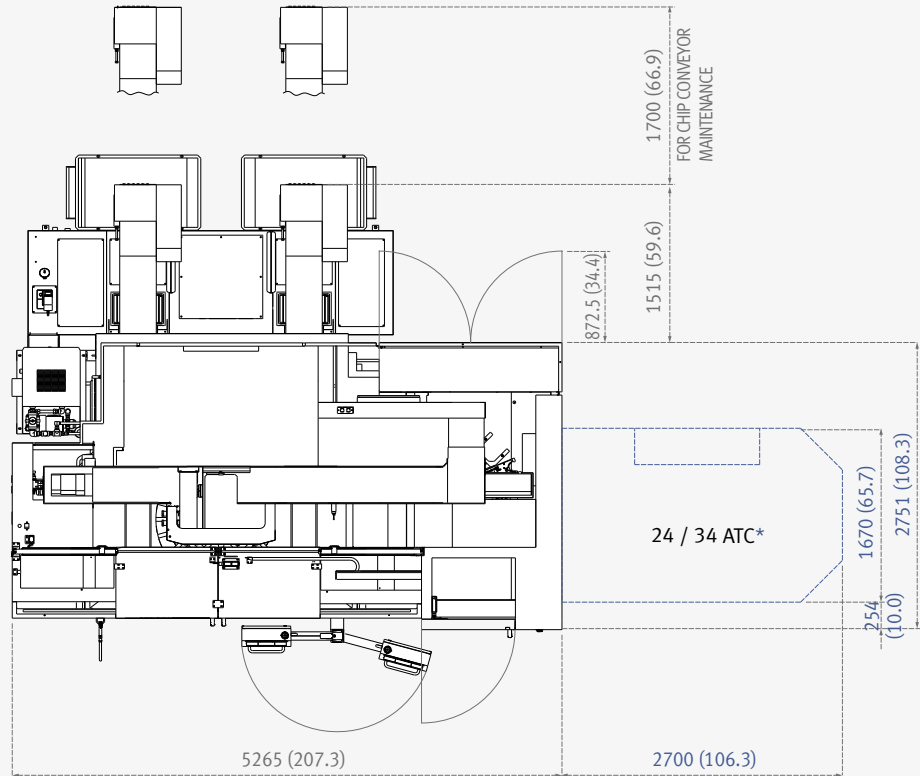

Front View

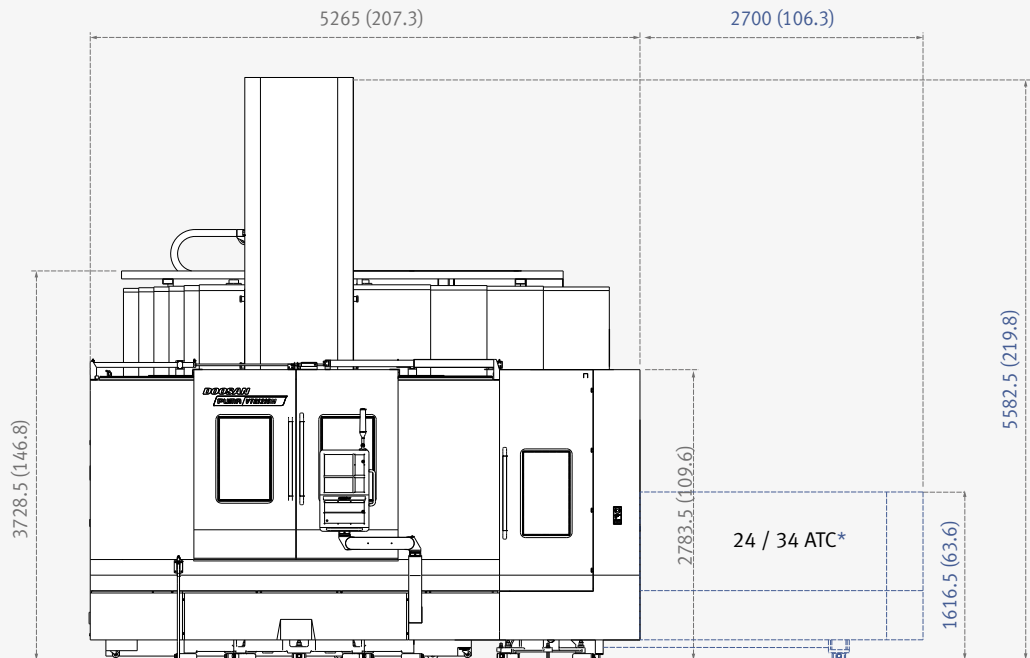

Top View

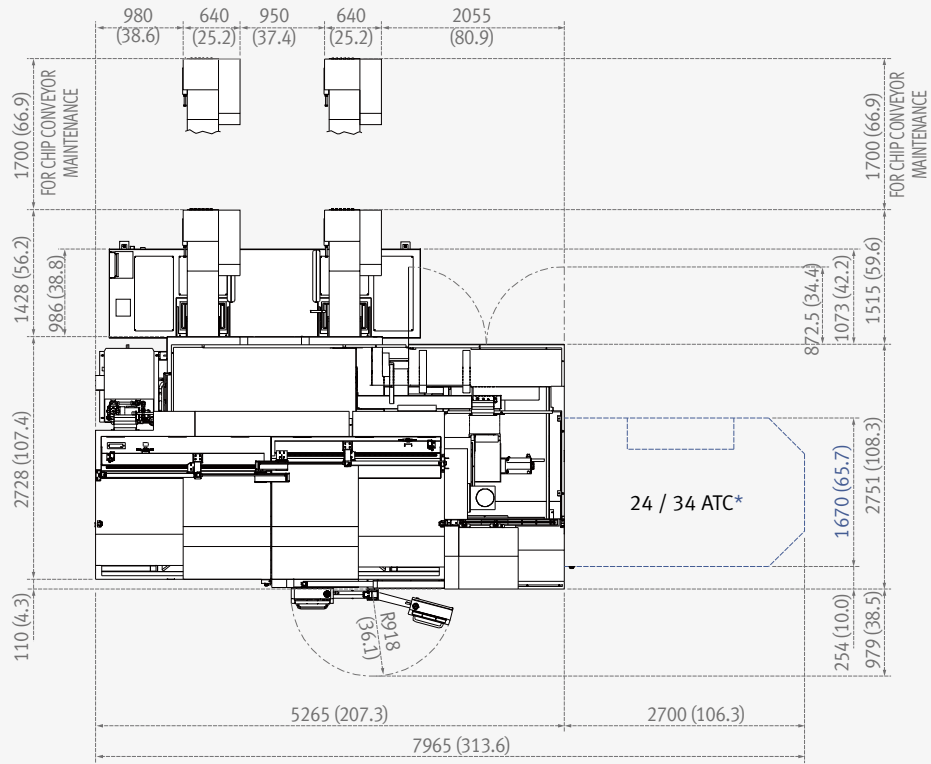

Front View

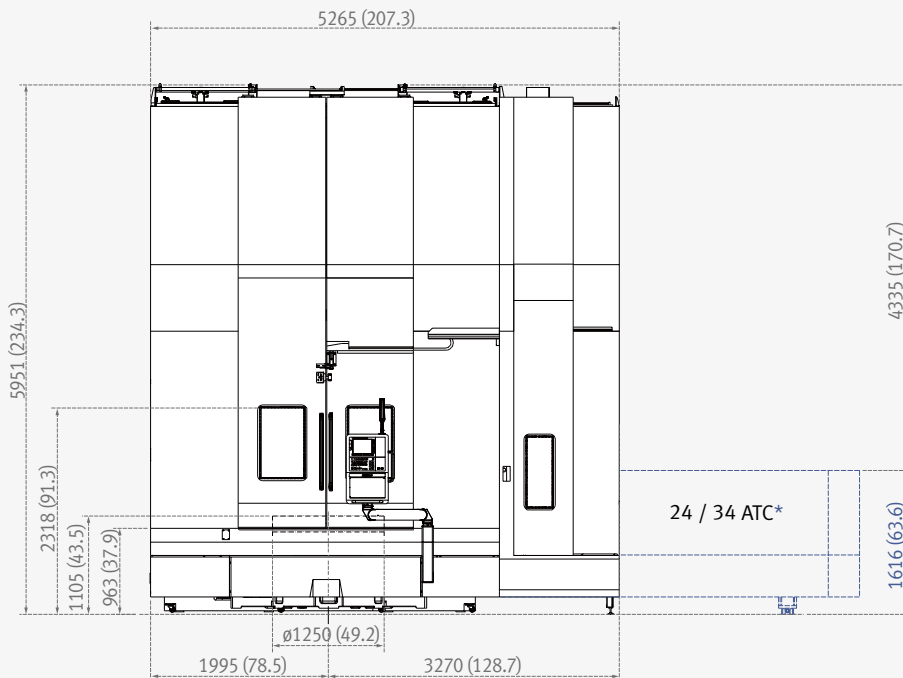

* only for 24/34 ATC

Tooling System

PUMA VTR1216/M

Unit: mm (inch)

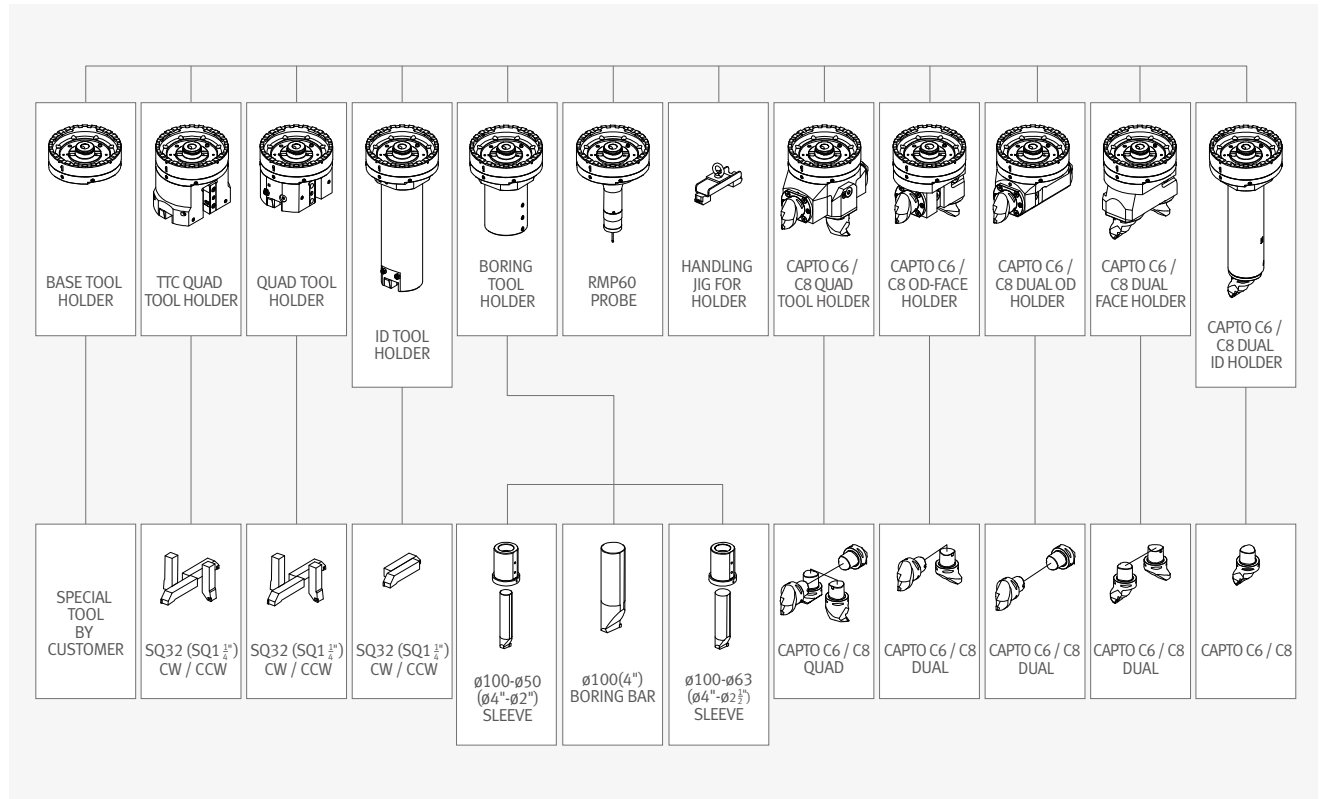

PUMA VTR1216M

Unit: mm (inch)

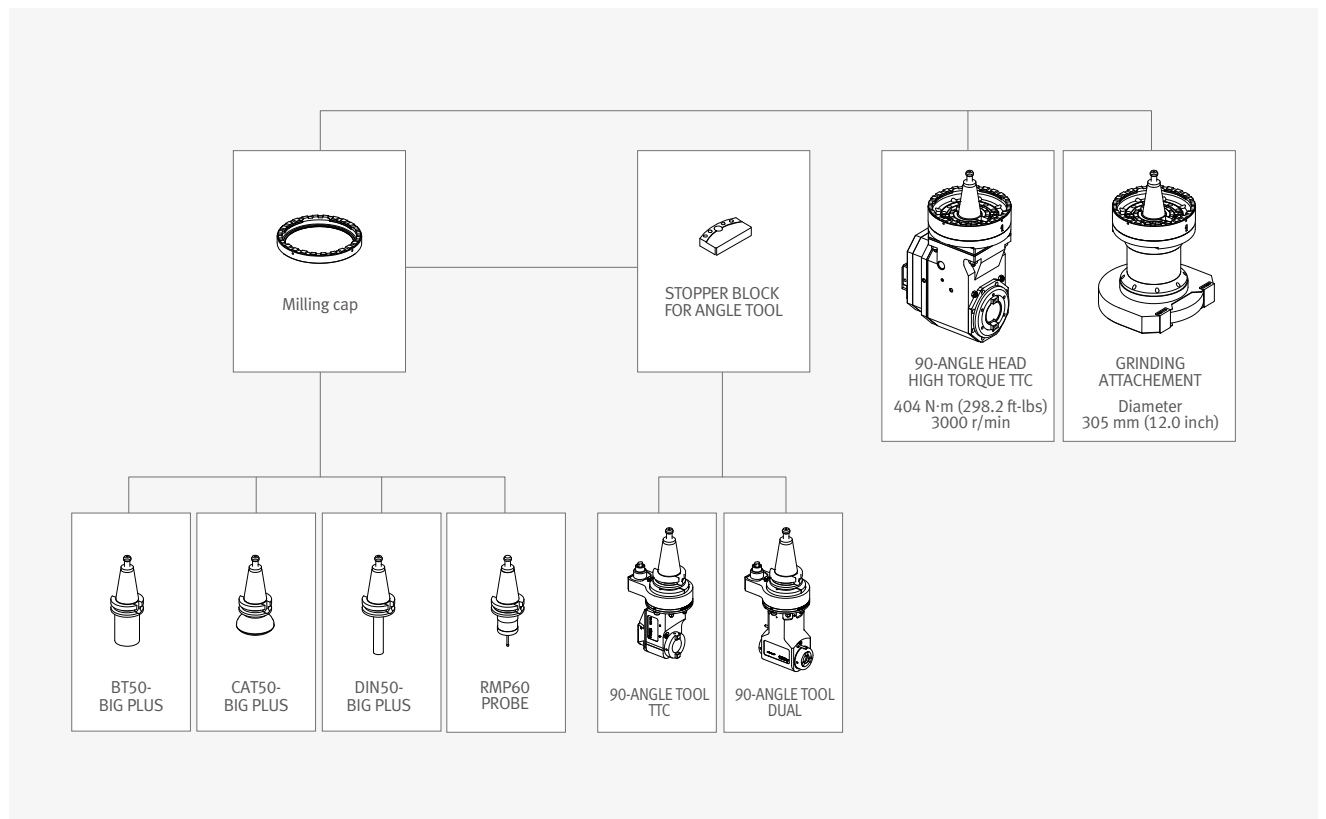

Tooling Attachment

PUMA VTR1216/M

Unit: mm (inch)

BASE TOOL HOLDER option

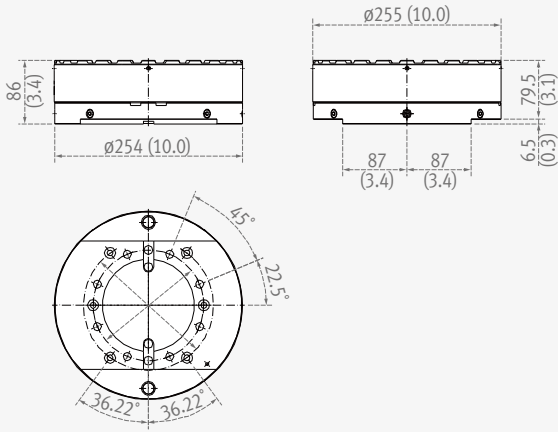

QUAD TOOL HOLDER option

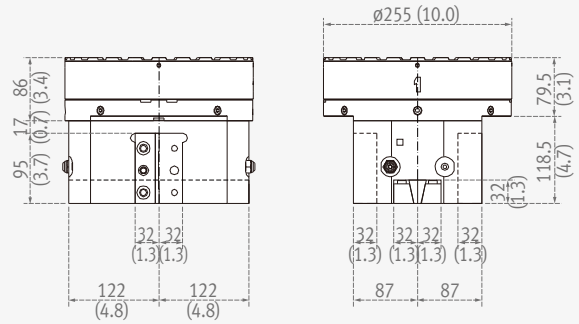

ID TOOL HOLDER option

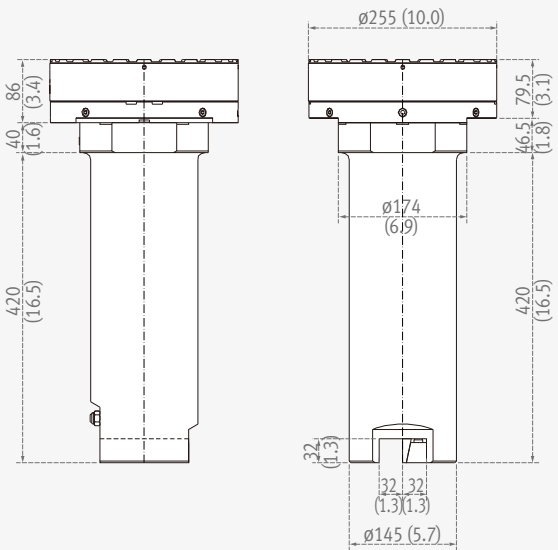

BORING TOOL HOLDER option

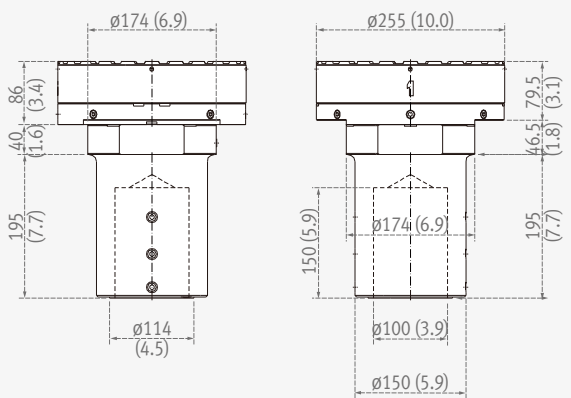

RMP60 PROBE option

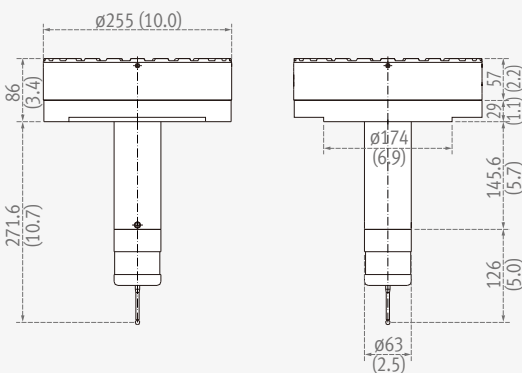

CAPTO-C8 QUAD TOOL HOLDER option

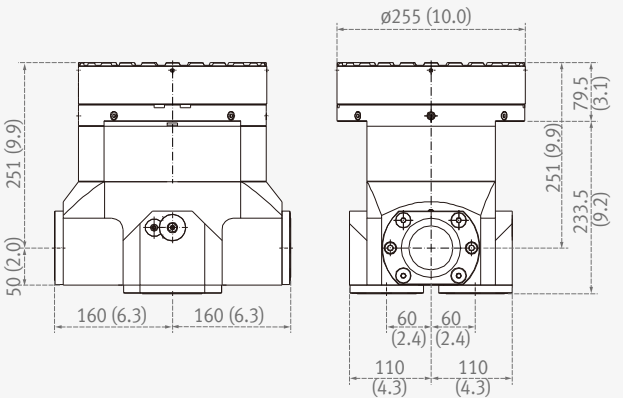

CAPTO-C8 OD-FACE HOLDER option

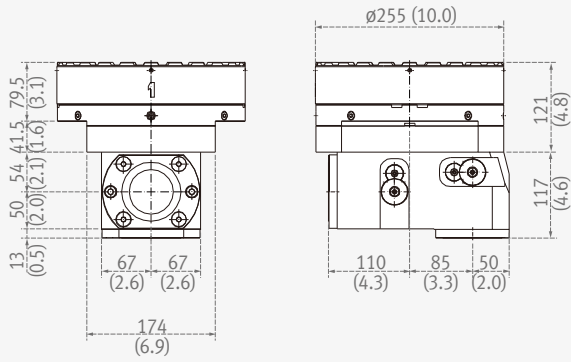

CAPTO-C8 DUAL FACE HOLDER option

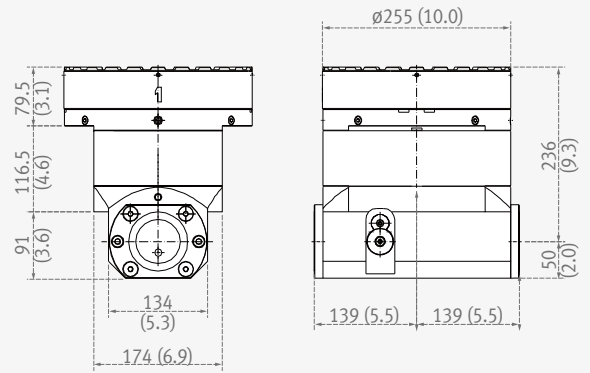

CAPTO-C8 DUAL-OD HOLDER option

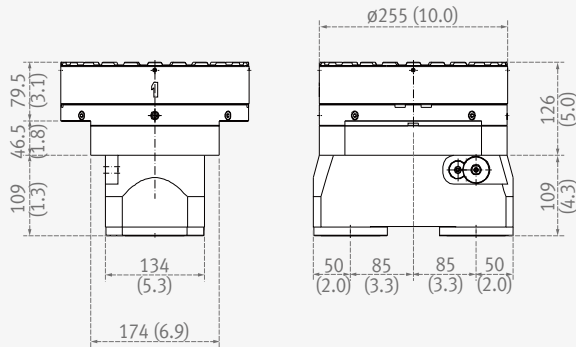

MILLING CAP option

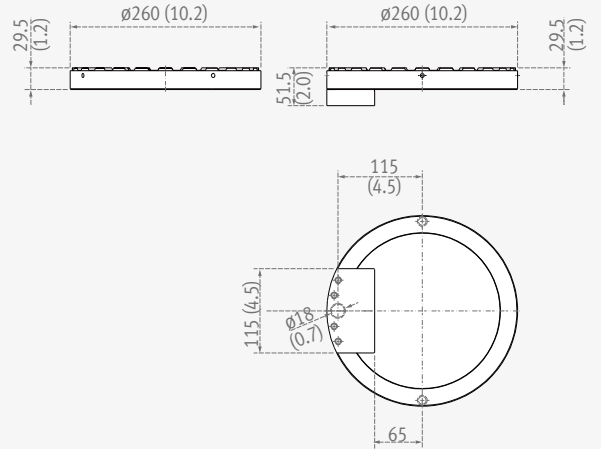

90-ANGLE TOOL TTC option

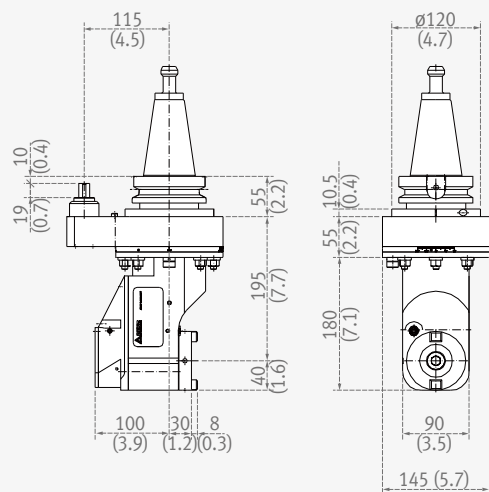

90-ANGLE TOOL DUAL option

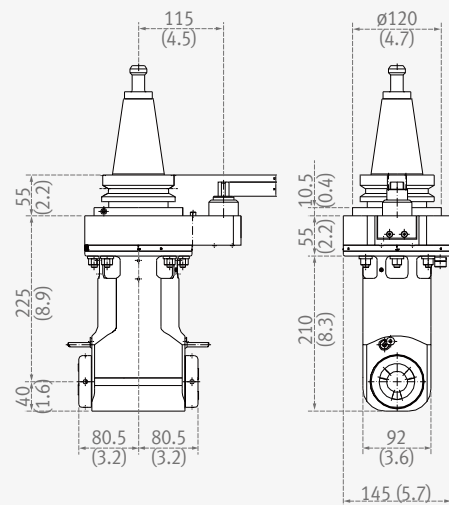

Tooling Attachment

PUMA VTR1216/M

Unit: mm (inch)

90 angle high torque TTC option

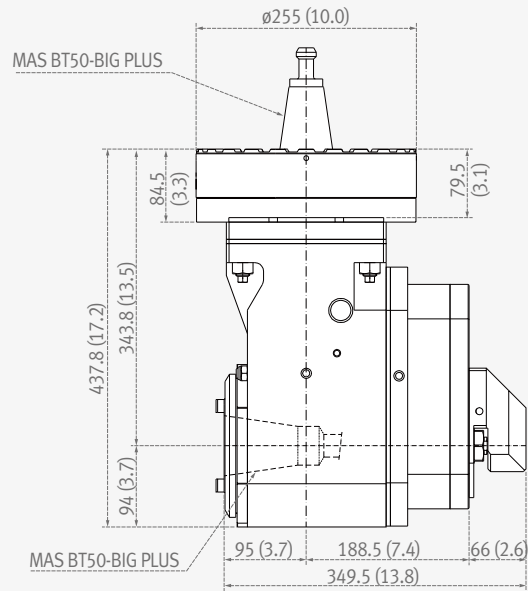

Grinding attachment option

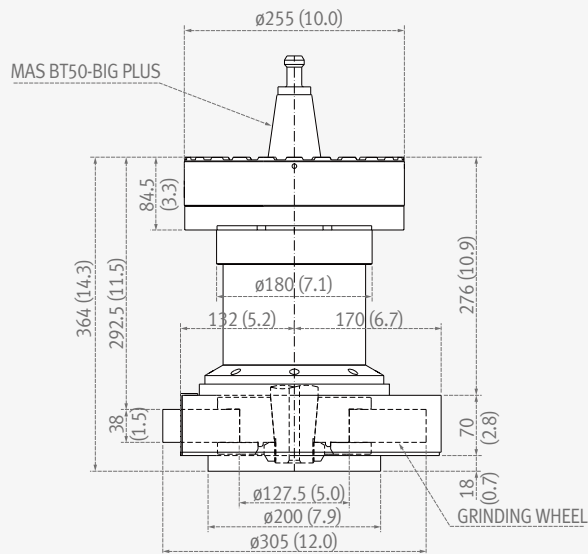

Quad Tool Holder

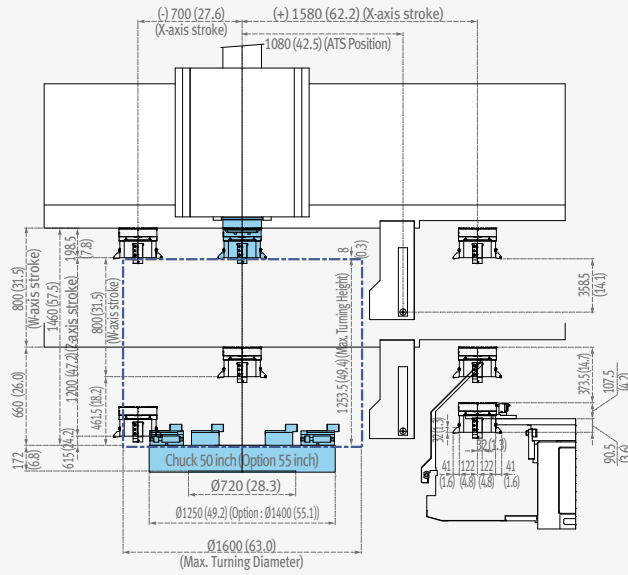

ID Holder

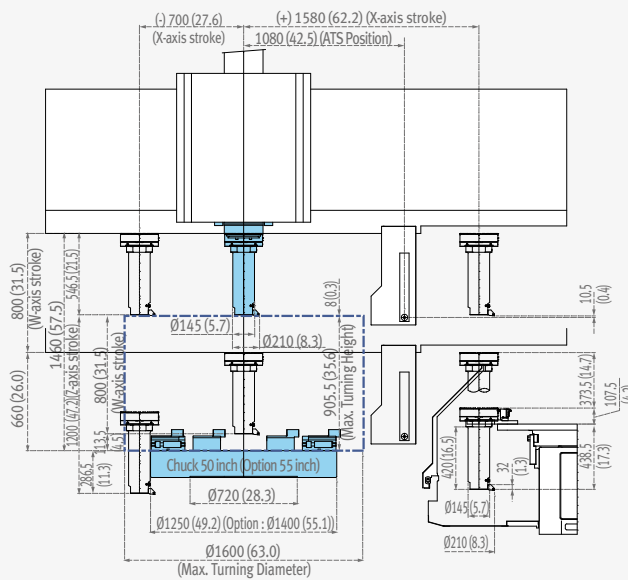

Boring Bar Holder

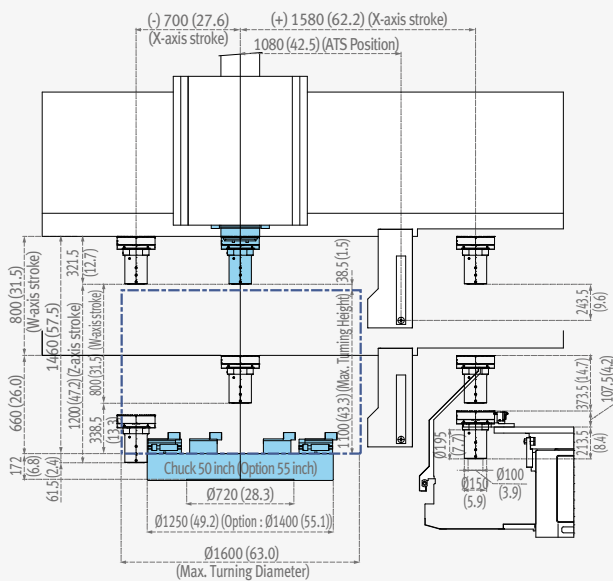

Milling Tool

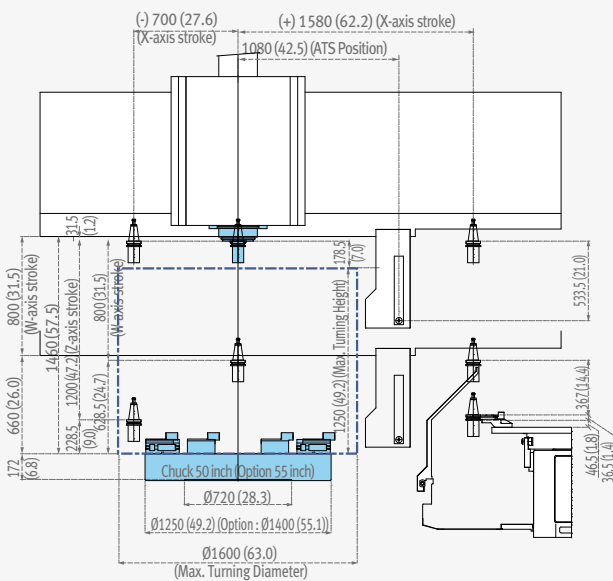

Angular Head

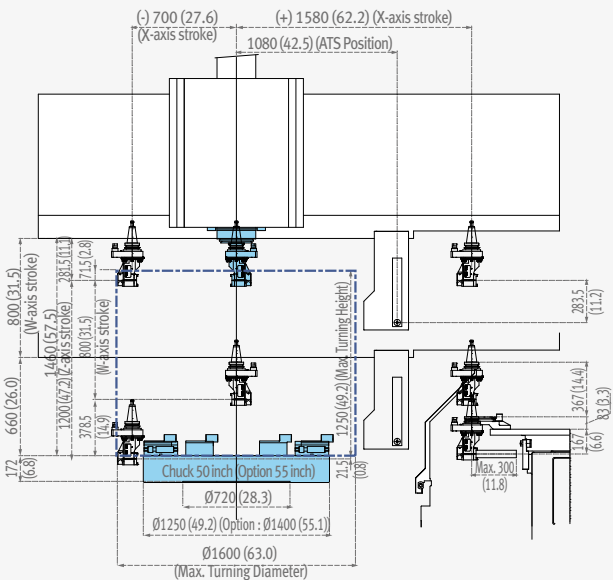

Tool Interference Diagram

PUMA VTR1216 (12-ATC)

Unit: mm (inch)

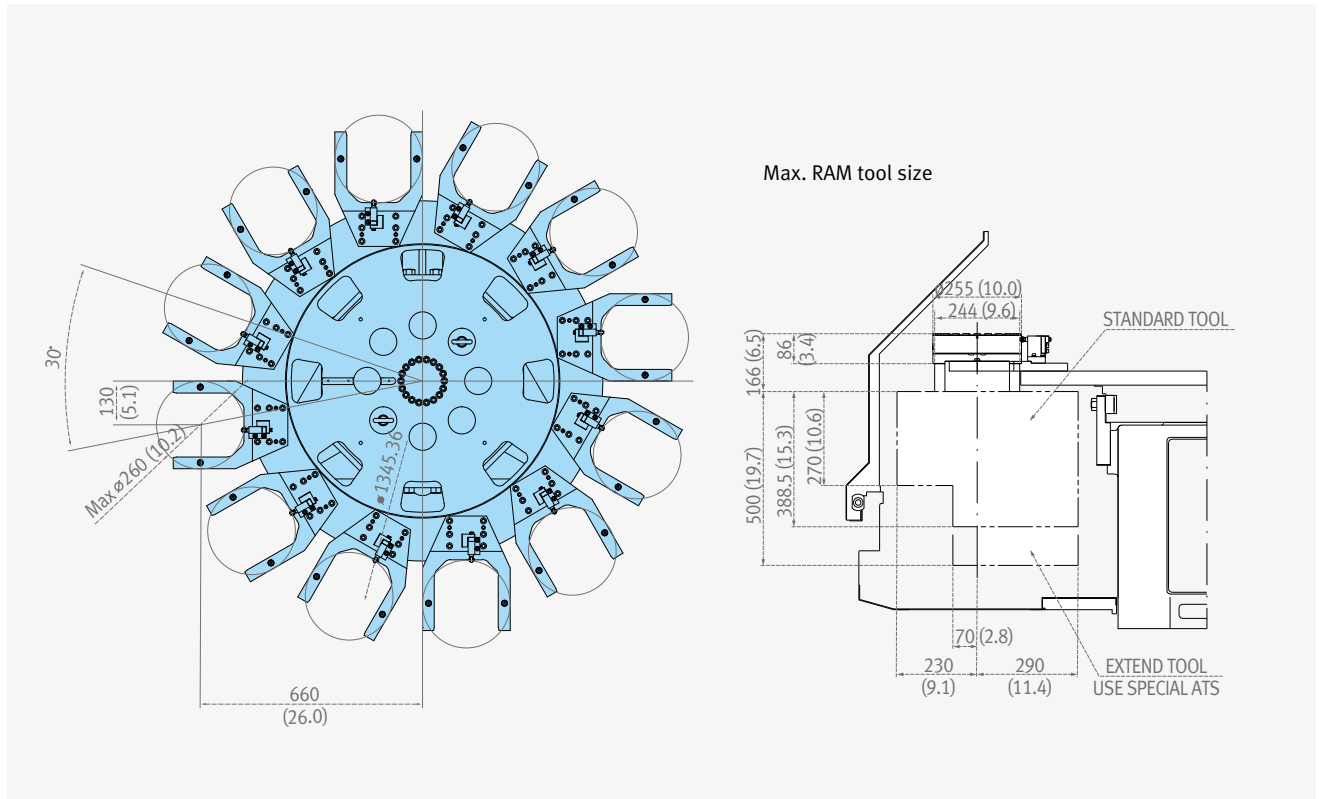

PUMA VTR1216 (15-ATC)

Unit: mm (inch)

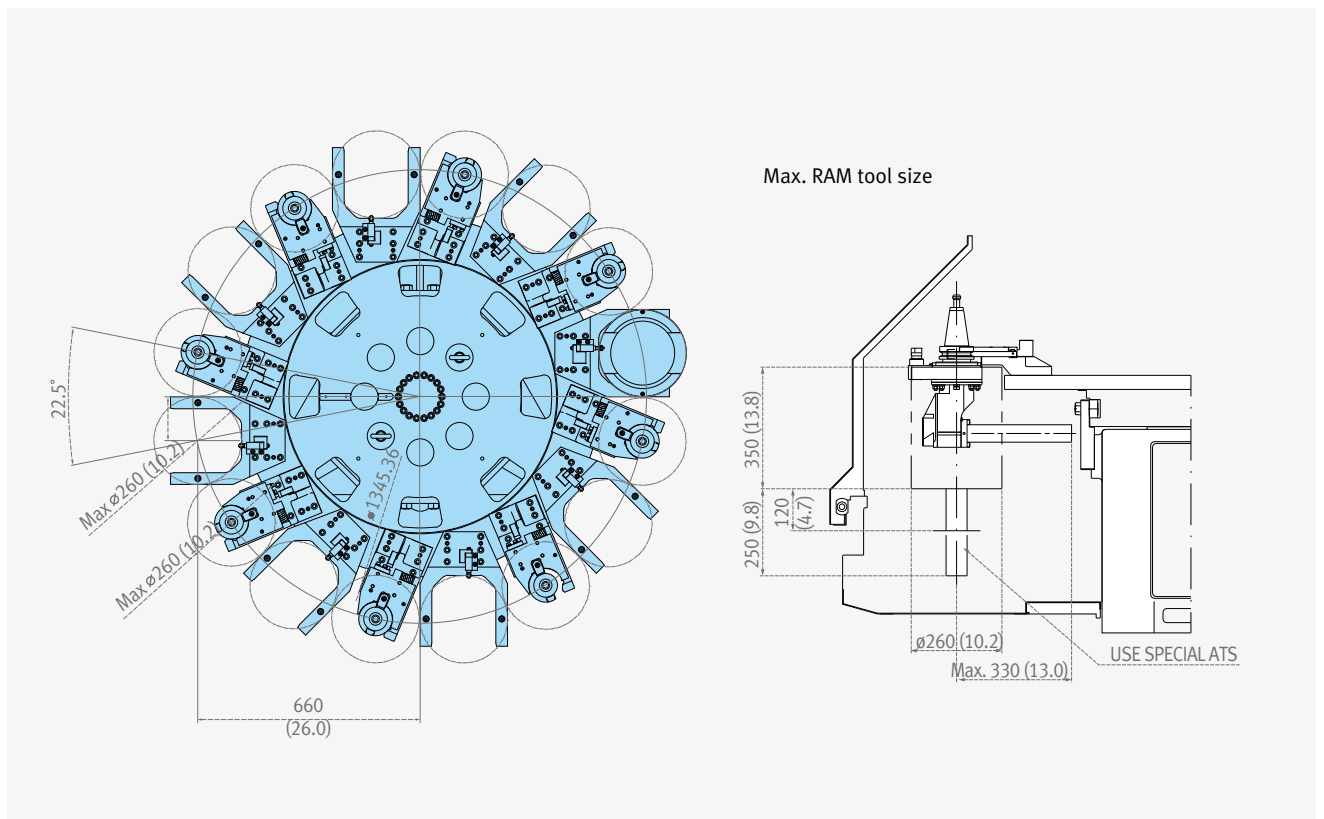

Machine Specifications



Description		Unit	PUMA VTR1216	PUMA VTR1216M
Capacity	Swing over bed	mm (inch)	1700 (66.9)	
	Recommended turning diameter	mm (inch)	1250 (49.2)	
	Max. turning diameter	mm (inch)	1600 (63.0)	
	Max. turning height	mm (inch)	1250 (49.2)	
	Max. allowable workpiece weight	kg (lb)	8000 (10,728.0)	
Travel	Travel distance	X-axis	-700 ~ 1000 (-27.6 ~ 39.4)	
		Z-axis	1200 (47.2)	
	W-axis	800 (200 x 4step) (31.5 (7.9 x 4step))		
Feedrate	Rapid traverse	X-axis	12	
		Z-axis	10	
Spindle	Spindle Max. speed	r/min	400	
	Spindle Max. power (30min/cont.)	kW (Hp)	45/37 {HV** : 70(S3 25%)/45/37}* (60.3/49.6 {HV** : 93.9(S3 25%)/60.3/49.6}*)	
	Spindle Max. torque	N·m (ft-lbs)	20557 {HV** : 31997}* (15171.1 {HV** : 23613.8}*)	
	C-axis min.indexing angle	deg	-	0.001
Tool magazine	No.of tool gripper	ea	12 / 24	15 / 33
	Magazine indexing time(1st)	sec	5.0	
	Max.tool length	mm (inch)	500 (19.7)	
Tooling	OD/Face tool	mm (inch)	32 (1.3)	
	ID Tool size	mm (inch)	32 (1.3)	
	Boring Bar diameter	mm (inch)	100 (3.9)	
	Tool clamping force	kN	Turning tool : 78.5 Milling too : 23.5	
RAM	RAM size	mm (inch)	260 x 260 (10.2 x 10.2)	
Milling spindle	Spindle Max. speed	r/min	-	3000
	Spindle Max. power (30min / cont.)	kW (Hp)	-	18.5/15/11 {HV** : 15/11}* (24.8/20.1/14.8 {HV** : 20.1/14.8}*)
	Spindle Max. torque	N·m (ft-lbs)	-	674 (497.4)
Power source	Power consumption	kva	120	120
Machine dimensions	Length x width	mm (inch)	5265 x 3824 (207.3 x 150.6)	
	Height	mm (inch)	5583 (219.8)	
	Weight	kg (lb)	29500 (65035.4)	30000 (66137.7)
Control	CNC system		DOOSAN-FANUC i	

* { } : option ** HV : High voltage CNC

Basic Information

Basic Structure

Detailed Information

Options

Applications

Diagrams

Specifications

Customer Support

Service

DOOSAN
FANUC i

NO.	Division	Item	Spec.	PUMA VTR1216	PUMA VTR1216M
1	Controlled axis	Simultaneously controlled axes		2 axes(X, Z)	3 axes(X, Z, C)
2		Cs contouring control		X	●
3		Torque control		●	●
4		HRV2 control		●	●
5		Inch/metric conversion		●	●
6		Stored stroke check 1		●	●
7		Stored stroke check 2, 3		●	●
8		Stored limit check before move		●	●
9		Chamfering on/off		●	●
10		Unexpected disturbance torque detection function		●	●
11		Position switch		●	●
12	Operation	DNC operation	Included in RS232C interface.	●	●
13		DNC operation with memory card		●	●
14		Tool retract and recover		○	○
15		Wrong operation prevention		●	●
16		Dry run		●	●
17		Single block		●	●
18		Reference position shift		●	●
19		Handle interruption		○	○
20		Incremental feed	x1,x10,x100	●	●
21		Manual handle retrace		○	○
22		Active block cancel		○	○
23	Interpolation functions	Nano interpolation		●	●
24		Linear interpolation		●	●
25		Circular interpolation		●	●
26		Polar coordinate interpolation		X	●
27		Cylindrical interpolation		X	●
28		Helical interpolation		X	○
29		Thread cutting, synchronous cutting		●	●
30		Multi threading		●	●
31		Thread cutting retract		●	●
32		Continuous threading		●	●
33		Variable lead thread cutting		●	●
34		Circular thread cutting		○	○
35		Polygon machining with two spindles		X	●
36		High-speed skip	Input signal is 8 points.	○	○
37		2nd reference position return	G30	●	●
38	3rd/4th reference position return		●	●	
39	Feed function	Override cancel		●	●
40		AI contour control I		○	○
41		AI contour control II		○	○
42		Rapid traverse block overlap		●	●
43	Program input	Optional block skip	9 pieces	●	●
44		Absolute/incremental programming	Combined use in the same block	●	●
45		Diameter/Radius programming		●	●
46		Automatic coordinate system setting		●	●
47		Workpiece coordinate system	G52 - G59	●	●

● Standard ○ Optional ✕ Not applicable

NO.	Division	Item	Spec.	PUMA VTR1216	PUMA VTR1216M
48	Program input	Workpiece coordinate system preset		●	●
49		Direct drawing dimension programming		●	●
50		G code system	A	●	●
51		G code system	B/C	●	●
52		Chamfering/Corner R		●	●
53		Custom macro		●	●
54		Addition of custom macro common variables	#100 - #199, #500 - #999	●	●
55		Interruption type custom macro		●	●
56		Canned cycle		●	●
57		Multiple repetitive cycles	G70~G76	●	●
58		Multiple repetitive cycles II	Pocket profile	●	●
59		Canned cycle for drilling		●	●
60		Coordinate system shift		●	●
61		Direct input of coordinate system shift		●	●
62	Pattern data input		●	●	
63	Operation Guidance Function	EZ GuideI(Conversational Programming Solution)		●	●
64		Easy Operation package		●	●
65	Auxiliary/ Spindle speed function	Constant surface speed control		●	●
66		Spindle override	0 - 150%	●	●
67		Spindle orientation		●	●
68		Rigid tap		●	●
69		Arbitrary speed threading		○	○
70	Tool function/ Tool compensation	Tool offset pairs	200-pairs	○	○
71		Tool offset		●	●
72		Tool radius/Tool nose radius compensation		●	●
73		Tool geometry/wear compensation		●	●
74		Automatic tool offset		●	●
75		Direct input of offset value measured B		●	●
76		Tool life management		●	●
77	Accuracy compensation function	Backlash compensation for each rapid traverse and cutting feed		●	●
78		Stored pitch error compensation		●	●
79	Editing operation	Part program storage size & Number of registerable programs	1280M(512KB)_400 programs	●	●
80		Part program storage size & Number of registerable programs	5120M(2MB)_400 programs	○	○
81		Program protect		●	●
82		Password function		●	●
83		Playback		●	●
84	Data input/output	Fast data server		○	○
85		External data input		●	●
86		Memory card input/output		●	●
87		USB memory input/output		●	●
88		Automatic data backup		●	●
89	Interface function	Embedded Ethernet		●	●
90		Fast Ethernet		○	○
91	Robot interface	Robot interface with PMC I/O module		○	○
92		Robot interface with PROFIBUS-DP		○	○
93	Others	Tool Load Monitoring function		●	●
94		Display unit	10.4" color LCD	●	●

Responding to Customers Anytime, Anywhere



Global Service Support Network

Corporations

5

Dealer Networks

122

Technical Centers

18

Factories

3

Technical Center: Sales Support, Service Support, Parts Support

Doosan Machine Tools' Global Network, Responding to Customer's Needs nearby, Anytime, Anywhere

Doosan machine tools provides a system-based professional support service before and after the machine tool sale by responding quickly and efficiently to customers' demands. By supplying spare parts, product training, field service and technical support, we can provide top class support to our customers around the world.



Domestic Service Support Network

Integrated Support Centers	2	Sales Branch Offices	7	Post-Sales Service Centers	6	Designated Repair Service Centers	31
----------------------------	---	----------------------	---	----------------------------	---	-----------------------------------	----

Customer Support Service

We help customers to achieve success by providing a variety of professional services from pre-sales consultancy to post-sales support.

Supplying Parts



- Supplying a wide range of original Doosan spare parts
- Parts repair service

Field Services



- On site service
- Machine installation and testing
- Scheduled preventive maintenance
- Machine repair

Technical Support



- Supports machining methods and technology
- Responds to technical queries
- Provides technical consultancy

Training



- Programming / machine setup and operation
- Electrical and mechanical maintenance
- Applications engineering

PUMA VTR1216 series



Description		Unit	PUMA VTR1216	PUMA VTR1216M
Capacity	Max machining dia.	mm (inch)	1600 (63.0)	
	Max machining height	mm (inch)	1250 (49.2)	
	Max table load	kg (lb)	8000 (1763.7)	
Travel distance	X axis (left / right)	mm (inch)	-700 / +1000 (-27.6 / +39.4)	
	Z / W axis	mm (inch)	1200 / 800 (47.2 / 31.5)	
Rapid traverse rate	X / Z axis	m/min (ipm)	12 / 10 (472.4 / 393.7)	
Main spindle	Max spindle speed	r/min	400	
	Max. spindle motor power	kW (Hp)	45 {70}* (60.3 {93.9}*)	
	Max spindle torque	N·m (ft·lb)	20557 {31997}* (15171.1 {23613.8}*)	
Tool magazine	Max tool position	ea	12 {24}*	15 {34}*
CNC system			DOOSAN-FANUC i	

*{ } Option



Doosan Machine Tools

<http://www.doosanmachinetools.com>

www.facebook.com/doosanmachinetools

www.youtube.com/c/DoosanMachineToolsCorporation

**MACHINE
GREATNESS™**

Head Office

Yeonkang Bldg., 6th FL., 270, Yeonji-dong,
Jongno-gu, Seoul, Korea
Tel +82-2-3670-5345 / 5362
Fax +82-2-3670-5382

Doosan Machine Tools America

19A Chapin Rd., Pine Brook, NJ 07058, U.S.A.
Tel +1-973-618-2500
Fax +1-973-618-2501

Doosan Machine Tools China

Room 101,201,301, Building 39 Xinzhuang Highway
No.258 Songjiang District,China Shanghai(201612)
Tel +86 21-5445-1155
Fax +86 21-6405-1472

Doosan Machine Tools Europe

Emdener Strasse 24, D-41540 Dormagen, Germany
Tel +49-2133-5067-100
Fax +49-2133-5067-111

Doosan Machine Tools Japan

#2412, Mita Kokusai Bldg. 1-4-28 Mita,
Minato-ku, Tokyo 108-0073, Japan
Tel +81 3 5730 9013
Fax +81 3 5730 9016

Doosan Machine Tools India

106 / 10-11-12, Amruthahalli, Byatarayanapura,
Bellary road, Bangalore-560 092, India
Tel +91-80-4266-0122 / 121 / 100

* For more details, please contact Doosan Machine Tools.

* The specifications and information above-mentioned may be changed without prior notice.

* Doosan Machine Tools Co., Ltd. is a subsidiary of MBK Partners. The trademark  **DOOSAN** is used under a licensing agreement with Doosan Corporation, the registered trademark holder.